

VSSP 300-700



Gearmotor

- SEW
- Other brands available on order

Materials

- Stainless AISI 304
- Stainless AISI 316

Delivery time

- 12-14 weeks

Sludge Applications

- Municipal
- Food industry
- Fish farming
- Oil and gas
- Process industry

VÅGEN Screw Press VSSP for thin sludge

This screw press is specially developed for dewatering thin sludge. It can be sludge from municipal or private treatment plants, sludge from the aquaculture industry or other similar processes.

The machine has 3 screen areas in which different screens can be inserted to optimize the sludge drainage.

The slow rotation provides a cost-effective, quiet and vibration-free operation with minimal maintenance and wear.

Different types of sludge give different results in relation to reject water quality and dry matter % in sludge cake, this can vary from 17-40% dry matter depending on sludge. The reject water is normally below 1000mg SS / liter.

Test machine

We are available to perform tests on your sludge to verify capacities, dry matter content and reject water quality before ordering. 2-3 days should be set aside for testing. Before testing, we need sludge samples sent for analysis. Contact us for a more detailed agreement.

Technical data

Model	L (mm)	W (mm)	H (mm)	W (kg)	Motor (kW)	Kg DS (kg/h)
VSSP 300	2650	760	1050	750	0,55	65*
VSSP 500	5100	1050	1250	2800	1,5	210*
VSSP 700	6200	1300	1500	4500	2,2	480*

*Capacity by sludge 2,5 % DS.

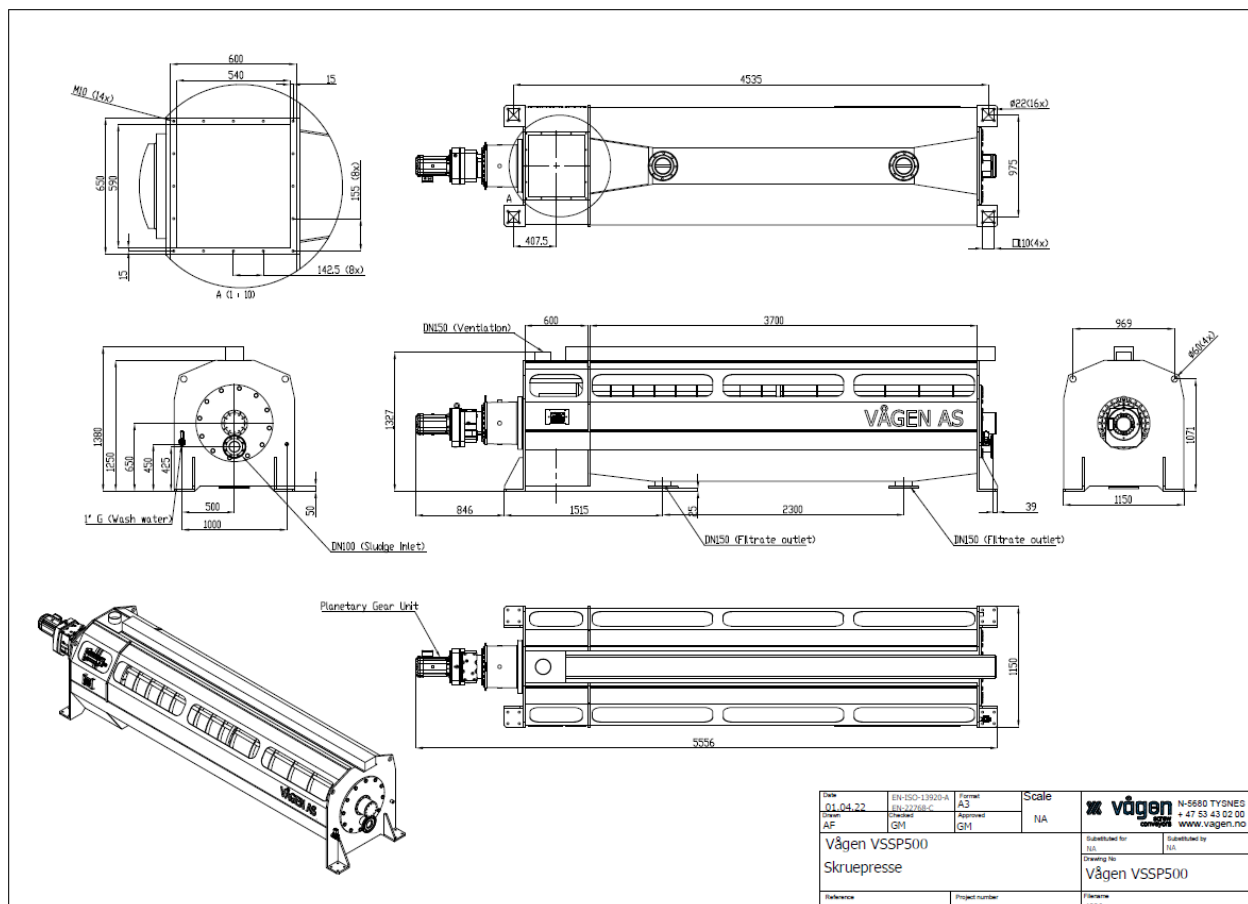

- Stainless steel 304 or stainless 316L.
- Large dewatering surface makes it possible to thicken and dewater in one machine.
- Fully automatic, self-cleaning screw press, for continuous sludge dewatering.
- Quiet, vibration-free operation due to low speed.
- Hole strainer in split design for easy maintenance and service.
- Completely closed design, provides a safe and hygienic working environment.
- Automatic adjustment of back pressure.
- The slow rotating screw requires a minimum of maintenance and wear is kept low.
- Frequency converters in operation

Kontakt oss for mer informasjon om våre tjenester og produkter

Vågen AS
Vågsmarka 9, 5680 Tysnes
T +47 53 43 02 00 | E vagen@vagen.no
W www.vagen.no