

SHAFTLESS SCREW PRESS

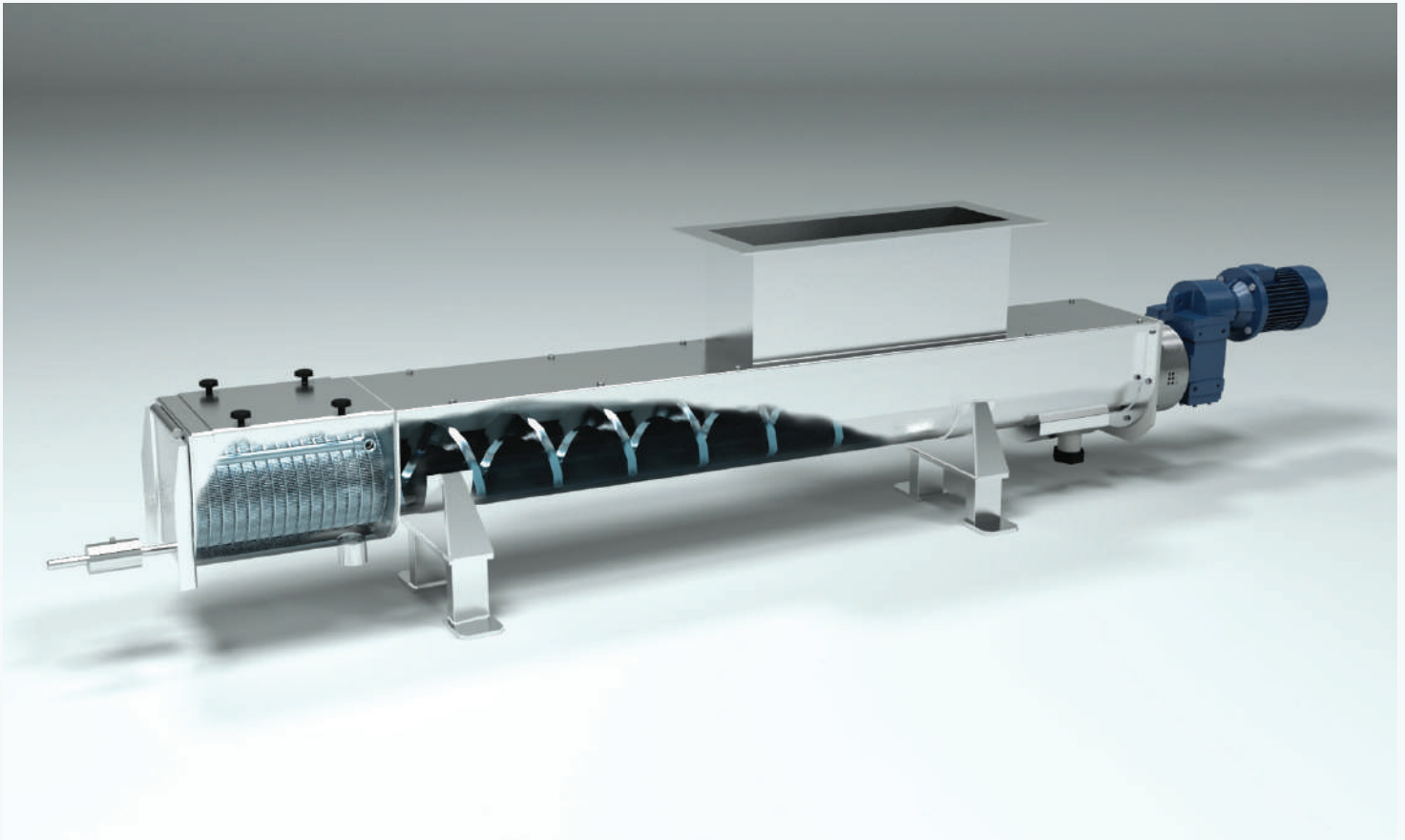

VSS 180-460

- Rotor with brush in strainer box ST 52,3
- Jet nozzle in strainer box
- Shaftless rotor
- Adjustable counterpressure
- 3 phase 230/400V
- 0,55kW-11kW

STRAINER

- Strainers 0,5mm-1mm
- Hole and slot strainers
- Stainless AISI 316

MATERIALS

- Stainless AISI 304
- Stainless AISI 316

VSS VÅGEN SHAFT LESS SCREW PRESS

In many cases it is necessary to separate liquids from solids. Mechanical dewatering is by far the most energy efficient method. Volume is reduced by 60-65%

Vågen's VSS Series is affordable, durable and easy to maintain. The presses supplied are hole or slot strainers depending on the mass to be by-watered. Slot strainers with a 1mm opening is standard.

We also deliver the applications you need, all acc. to Machinery Directive and ATEX. Simple start stop sequences or frequency control for optimum operation with different masses.

TYPE	STRAINER	WEIGHT	CAPACITY	LENGTH
VSS 180	412mm	240 kg	1,5 m ³ /h	3412mm
VSS 230	562mm	300 kg	4,0 m ³ /h	3562mm
VSS 280	662mm	360 kg	6,5 m ³ /h	3662mm
VSS 330	662mm	400 kg	9,0 m ³ /h	3662mm
VSS 380	666mm	530 kg	16 m ³ /h	3666mm
VSS 460	816mm	640 kg	24 m ³ /h	3816mm

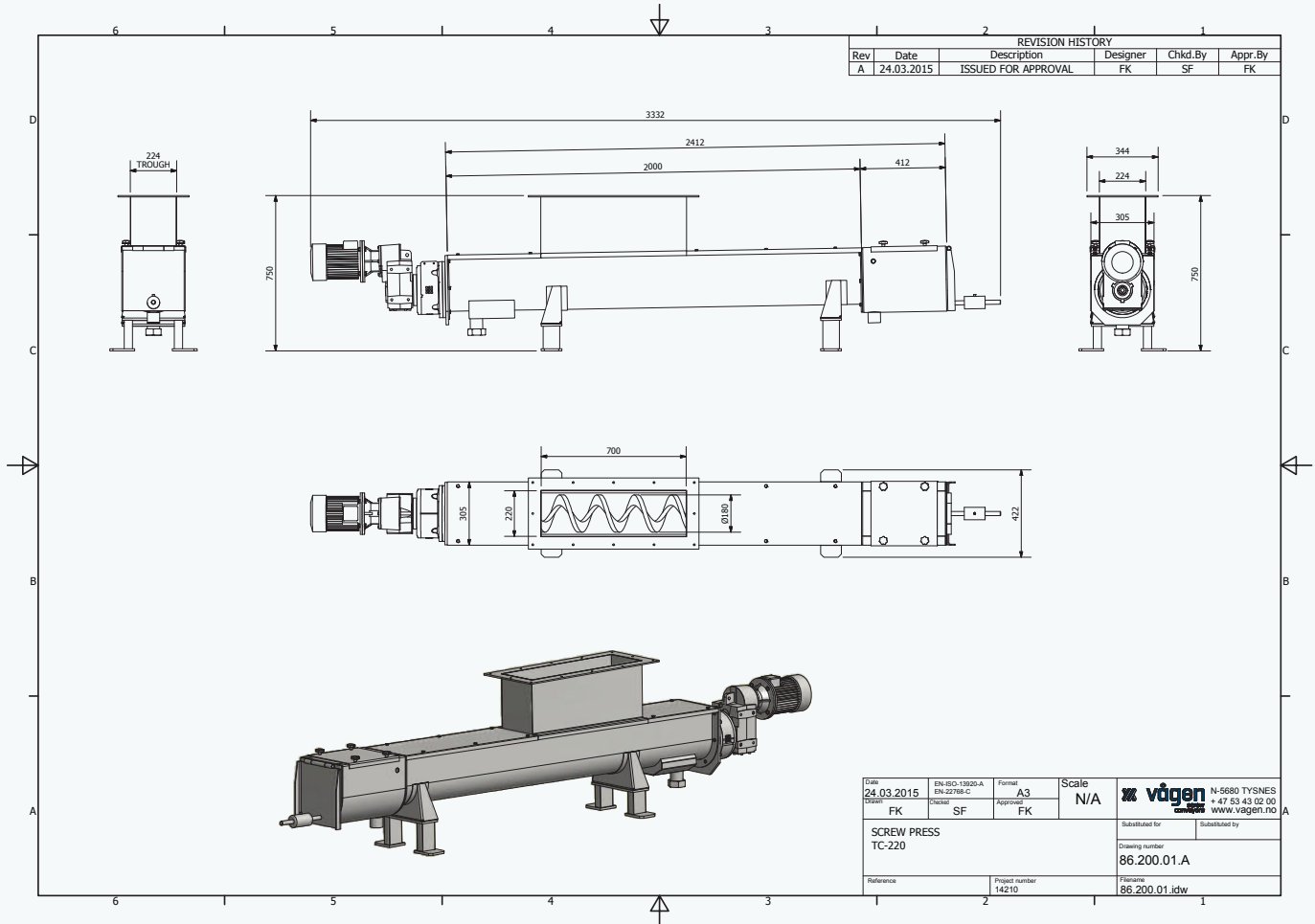

General Information.

- High quality, energy-efficient compact geared motors from SEW Eurodrive. Other drives can be supplied upon request.
- Available with aseptic gearmotors for the food sector industry, up to 1.5kW.
- Flange mounting for easy installation.
- Dewatering, low energy consumption.
- Manufactured in FDA approved material AISI 304 or other materials as desired.
- Reduces volume of wet massed by between 60-65%.
- Interchangeable strainers, hole strainers or slot strainers with custom opening.
- Connection for automatic flushing and cleaning of the sieve and screen box.
- Drain Plug for drainage of free water in the inlet end.
- Solids content up to ca. 30% depending on the mass of water.
- Standard inlet flange 700mm length.
- Feeding bin of 150 liters can be delivered.
- Support with wheels can be delivered.
- V-shaped slot strainers.
- Perforated strainers with slotted holes.
- Adjustable counterweight in outlet.
- Shaftless screw rotors.

Contact us for more information about our services and products.

Vågen AS

Vågsmarka 9, 5680 Tysnes

T +47 53 43 02 00 | **E** vagen@vagen.no

W www.vagen.no