

# STANDARD SCREW CONVEYORS

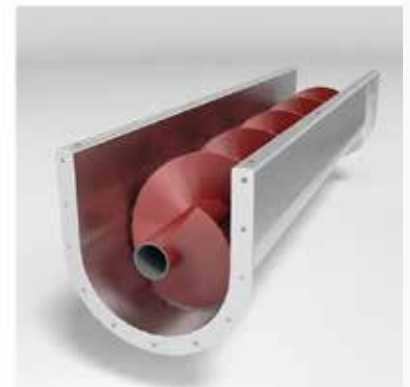
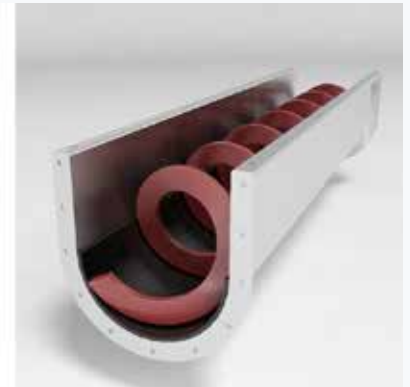

## U-TROUGH

Carbon steel S235/S355

Stainless steel AISI 304

Stainless steel AISI 316

## PIPE-TROUGH

Carbon steel S235/S355

Stainless steel AISI 304

Stainless steel AISI 316

## ROTORS

With central shaft

Without central shaft

Carbon steel or AISI 304/316

## DRIVE UNITS

- ABB
- DANFOSS HYDRAULIC
- SEW
- SIEMENS
- WEG/TEM

## STANDARD SCREW CONVEYORS

We have developed STANDARD Screw Conveyors which can easily be assembled to different lengths, for the most common dimensions.

Screw rotors come with or without a central shaft.

Screw Conveyors are delivered with electrical or hydraulic drive units.

We also deliver the start applications and control systems you need, all in accordance with applicable specifications.

Simple start/stop or frequency converters for optimal running and speed regulation.

## STANDARD SCREW CONVEYORS IN STOCK

Ø350mm rotors are kept in stock for urgent deliveries. These can be assembled in combinations of 2 and 3 meter lengths.

U-trough manufactured in stainless steel AISI 316.

Rotor with central shaft in carbon steel.

Stocked: SSC-80-350[14"]

TYPE	LENGTH	DIAMETER	CAPACITY	ANGLE
TROUGH	2000/3000	U 370	0-28 m <sup>3</sup> /h	0-45 °
ROTOR	2000/3000	Ø 350[14"]	-	-

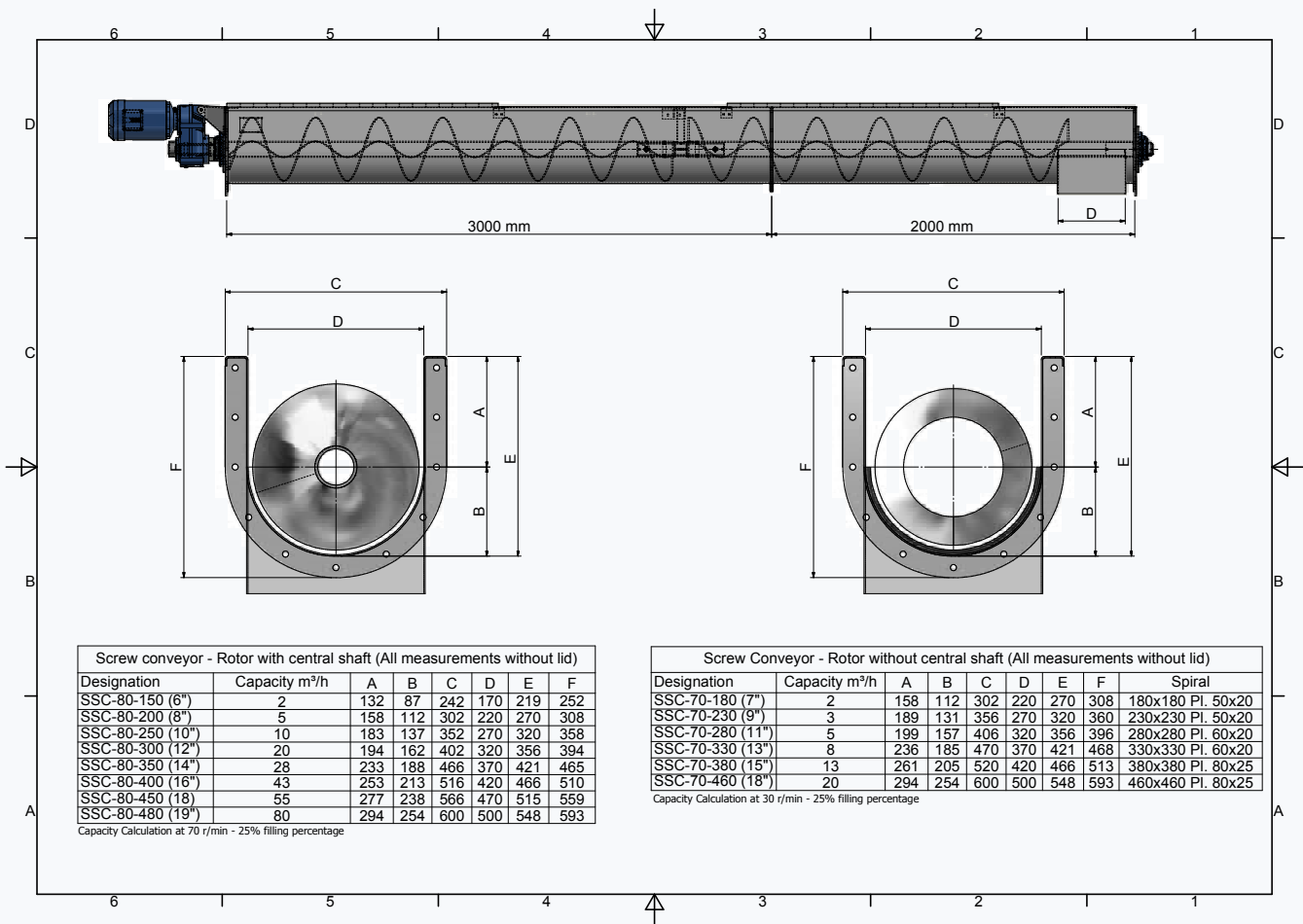

## General information

- Stocked Ø350mm[14"]
- Short assembly time
- High quality, effective drive units from well known suppliers.
- Motor with low energy consumption
- 2 or 3 metre lengths which can be assembled almost unlimited.
- Rotors with or without a central shaft
- Troughs in polyethylene, carbon steel S235-355, Stainless steel AISI 304/316.
- Rotors in carbon steel, stainless steel or Hardox.
- Solid covers or grating.
- Galvanized or painted.

- Custom made systems.
- Shaft seal rings or packin box shaft seals.
- Mounted in pillow block or flange bearings.
- Support or hangers.
- ATEX Zone 1 and 2 or 21 and 22.
- Motor starters and control systems.
- Electrical or hydraulic drive.

Contact us for more information  
about our services and products.

**Vågen AS**  
Vågsmarka 9. 5680 TYSNES NO

**T** +47 53 43 02 00  
**E** vagen@vagen.no  
**W** www.vagen.no